

**EROGATORI SOTTOBANCO**  
*UNDER COUNTER DISPENSER*



Optional

**18 l/h**  
**DRY UNDER**

- ✓ **Disponibile nella versione raffreddata ad acqua**  
*Available in the water cooled version*
- ✓ **Disponibile nella versione compatibile con rubinetto elettrico**  
*Available in the version compatible with electric tap*

**SW**



**CA**



mm

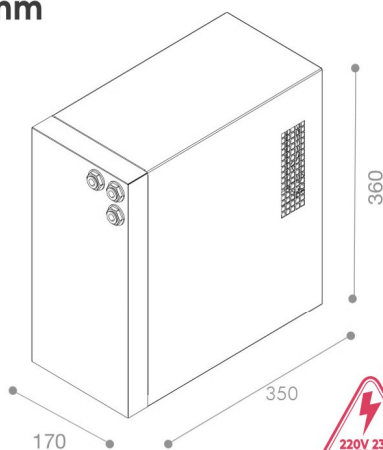

**1 pcs x 22kg**  
mm



Accessori/Accessories



Accessori/Accessories



- **EROGATORE SOTTOBANCO A 2/3 SELEZIONI PER ACQUA A TEMPERATURA AMBIENTE, ACQUA REFRIGERATA, ACQUA GASSATA REFRIGERATA**
  - **SISTEMA DI REFRIGERAZIONE A SECCO CON BLOCCO D'ALLUMINIO (ISOLAMENTO ISOTECH PLUS)**
  - **DISPONIBILE CON SISTEMA DI EROGAZIONE A COMANDO IDRAULICO (I) O ELETTRICO (E)**
  - **DISPONIBILE CON CONDENSAZIONE AD ACQUA (H<sub>2</sub>O)**
  - **CARENATURA ESTERNA IN SKIN PLATE**
- 
- **UNDER COUNTER WATER DISPENSER WITH 2 OR 3 SELECTIONS: ROOM TEMPERATURE STILL WATER, COLD STILL WATER, COLD SPARKLING WATER**
  - **DRY COOLING SYSTEM WITH ALUMINUM BLOCK (ISOTECH PLUS ISOLATION TECHNOLOGY)**
  - **AVAILABLE WITH MANUAL (I) OR ELECTRIC (E) DISPENSING SYSTEM**
  - **AVAILABLE WITH WATER CONDENSATION (H<sub>2</sub>O)**
  - **SKIN PLATE HOUSING**

